



8' HORTICULTURAL LINEAR INTERLIGHTING FIXTURE



ACHIEVE BETTER RESULTS WITH SHARP LED INTERLIGHTING.

LED interlighting promotes efficient plant production and reduces energy consumption. When used as supplemental lighting, our interlighting enhances plant growth.

8' LINEAR INTERLIGHTING LED SYSTEM

GENERAL DESCRIPTION

Designed for greenhouse operation, our LED Interlighting promotes plant growth and flowering through the use of horizontal lighting to areas of the plant that do not receive adequate light from natural sun light or top lighting systems. Our flexible design allows greater control over the growth process. Our interlighting connections provides easy to install solutions.

FEATURES AND BENEFITS

- Easy to Install, interlighting connection between fixtures
- Energy efficient - uses up to 80% less energy than standard HPS.
- Reduced heat generation - LED technology and light heat sink design allow the fixture to be situated close to the plant for optimal light conditions.
- Slim elegant design ensures no additional shadowing.
- High efficiency, long life driver.
- 9:1 Red : Blue color ratio creates the best conditions for plant growth.
- 3 year limited warranty

APPLICATIONS

- Indoor Farms
- Supplemental Greenhouse Lighting
- Canopy Plants

PERFORMANCE SUMMARY

Photon Flux ($\mu\text{mol/s}$)	220
Color	Purple
Input Power	130 W
Input Voltage	120-277 V
Enclosure Rating	IP65
Rated Life	30,000 Hrs
Operating Temperature	-20 to 50 °C

WEIGHT

9.26 lbs / 4.2 kg

CERTIFICATIONS

ETL, cETL, FCC & ICES-003

Subject to change without notice.

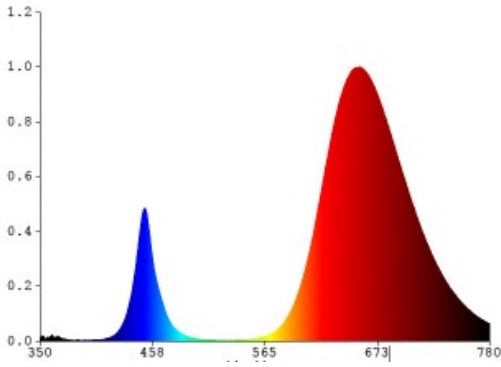

The 9:1 R:B ratio is the most efficient ratio for the widest variety of applications. It can be used with a variety of plant species during all of their growth stages. The high proportion of red light encourages photosynthesis through the vegetative growth stage and facilitates the flowering stage, while the blue light increases the rate of vegetative growth and reduces plant height, optimizing space utilization.



**INTERLIGHTING CONNECTIONS:
10 (120V), 20 (277V)**

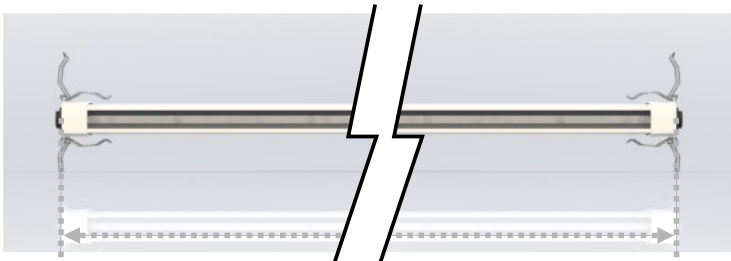

2445 mm

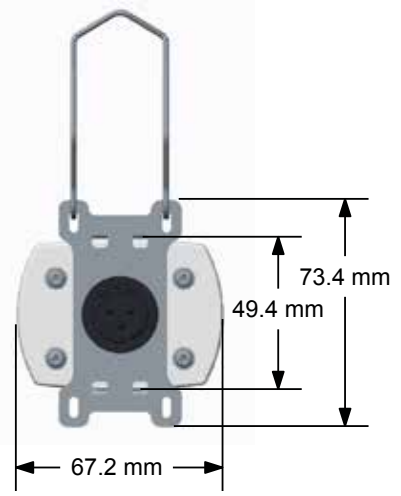

Dimensions: 96.26 (L) x 2.55 (W) x 2.89 (H) inch
2445 (L) x 67.2 (W) x 73.4 (H) mm

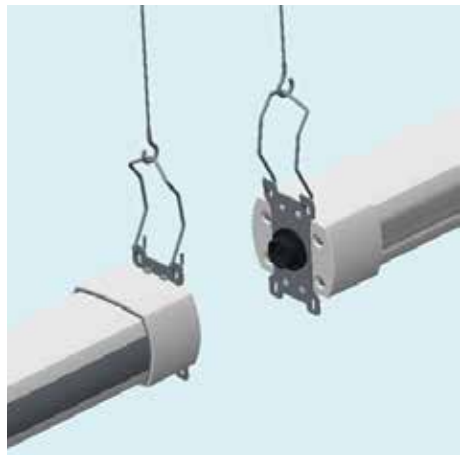

Ordering Guide : DL-LG8EP4

DL	L	G	8	E	P	4
Product Classification		Product Size		Lumination	Color	Voltage
DL On Grid	L Linear	G Grow	8 Rectangle 8'	E 220 - 249 Photon Flux	P Purple	4 120 - 277 V

SHARP

SHARP ELECTRONICS CORPORATION
Sharp Plaza Blvd., Memphis, TN 38193
1-877-312-5331 • Email: LEDsupport@sharppusa.com
www.sharpledlighting.com